

Fixture Type:	
Model Number:	
Project:	

CIS SERIES AC INVERTER SYSTEM

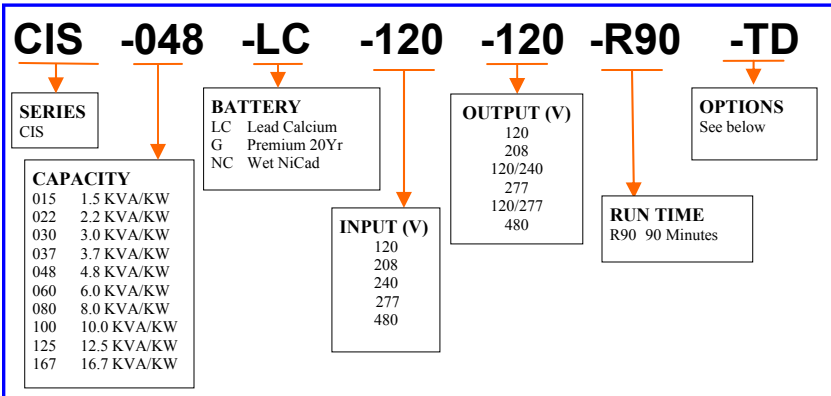

ORDERING GUIDE



PRODUCT FEATURES

- Pulse Width Modulated inverter design with IGBT technology
- "Off line" operation for increased reliability and efficiency
- 50ms transfer time
- Self-testing/self-diagnostic operation
- 97% efficiency rating at full load
- Harmonic distortion <10%
- Load power factor range .5 lead to .5 lag
- 1.5 KVA to 16.7 KVA models
- Compatible with all fluorescent, incandescent and LED lighting loads
- Backup generator compatible
- Microprocessor controlled, 20 character display with touch pad controls and functions
- User programmable with password protection
- Input circuit breaker standard
- Normally-Off output terminal standard
- RS-232 communications port
- Small footprint
- 90 minute operation standard, alternate runtimes available
- Maintenance-free lead calcium battery standard
- Optional long life lead calcium and wet-cell nickel cadmium batteries
- 68°F to 86°F (20°C to 30°C) operating range
- Meets NFPA Life Safety Code 101, NEC and OSHA
- UL924 listed

OPTIONS²

- CH** Charger upgrade
- M** Internal Bypass Switch
- IO** Inverter On Contacts
- S** Summary Alarm Contacts
- MOD** External Modem
- FAX** Fax Modem
- RMP** Remote Meter Panel
- RAP** Remote Alarm Panel
- Z** Seismic Bracing¹
- BCM** Battery Cycle Monitor
- TD** 15-Minute Re-transfer Delay
- OCB** Output Circuit Breaker - (See page 4 for details)
- AR** Alternate Run Time (Specify Time in Minutes)
- IDB** Internal Dimmer Bypass
- SNMP** Simple Network Monitoring Protocol
- SMC** Status Monitoring Contacts
- FS** Factory Start-Up (Includes One Additional Year Of Warranty on the electronics portion only)
- EW** Extended Warranty (Includes FS)
- EMBP** External Maintenance Bypass Switch

¹ System cabinetry may not be stacked on models specified with SEISMIC option - Brackets add 7 inches to the overall length

² Some options may impact product UL listing. Consult factory

Application

The CIS Series is designed to back up critical loads where transfer to emergency mode must be rapid. The CIS Series with Pulse Width Modulated design and fast, 50ms switching provides performance ideally suited for LED, fluorescent or incandescent lighting loads. Additionally, the CIS "off-line" design delivers superior reliability and increased MTBF.

Construction

Cabinetry: Freestanding heavy duty NEMA Type 1 steel cabinets are finished in neutral tan baked-on powder paint providing scratch and corrosion resistance.

Cooling: Electronics Cabinet: Convection in standby mode with forced air during emergency mode.

Battery Cabinets: Convection cooling. Auxiliary air conditioning units available for high temperature environments, consult factory.

Access: Front access via hinged, lockable doors on all electronics and battery cabinets.

Installation

Mounting: Freestanding cabinets bolt together when more than one cabinet is required. An optional seismic kit is available for securing systems in areas requiring earthquake resistance, see "Options" section on front of sheet for ordering details.

Code Information

UL924 Listed and meets NFPA 101 Life Safety Code, NFPA 70, NFPA 110, UBC, SBCCI, NEC and OSHA

Warranty Information

System:

1-year full coverage against defects in materials and workmanship from date of shipment

Batteries:

Standard Lead Calcium Battery: 1 year full warranty plus 9 years of pro-rata coverage

Optional Long Life Lead Calcium Battery: 1 year full warranty plus 19 years of pro-rata coverage

Optional Wet Nickel Cadmium Battery: 1 years full warranty plus 14 years of pro-rata coverage.

Electrical Specifications

Input

Input Voltages: (60Hz) 120, 208, 240, 277, 480 $\pm 10\%$

Input Frequencies: 60Hz $\pm 3\%$

Synchronizing Slew Rate: 1 Hz per second nominal

Harmonic Distortion: $<10\%$

Power Factor: 0.5 lead/lag

Input Protection: Circuit breaker

Output

Output Voltages: (60Hz) 120, 120/240, 120/277, 277 or 480

Static Voltage: Load current change $\pm 2\%$, Battery discharge $\pm 12.5\%$

Dynamic Voltage: $\pm 2\%$ for $\pm 25\%$ load step change, $\pm 3\%$ for $\pm 50\%$ load change.

Recovery within 3 cycles.

Output Frequencies: Synchronized to utility. 60 Hz $\pm .05\text{Hz}$ during emergency operation

Output Distortion: $<3\%$ THD (linear load)

Transfer Time: 50 ms

Load Power Factor Range: 0.5 Lead to 0.5 Lag

Minimum Loading: 5% of rated system capacity

Overload Protection: 125% for 5 minutes

Output Protection: Standard fuse or optional output circuit breakers

Batteries and Charger

Charger Type: Fully automatic, microprocessor controlled, temperature compensating

Recharge Duty Cycle: 24 hours

Charger Protection: Fused output and automatic low voltage battery disconnect

Standard Battery: Sealed Lead Calcium (10 year life) - Type LC

Optional Batteries: Sealed Lead Calcium (20 year life) - Type G

Wet-cell Nickel Cadmium (25 year life) - Type NC

Battery Voltage: 48 to 240VDC (depending on system rating)

Runtime: 90 minutes standard - based on battery performance at 77°F (25°C). Other runtimes available, consult factory.

Environmental

Altitude: $< 10,000$ feet (3,000m) above sea level without de-rating

Operating Temperature Range: Optimum performance between 68°F and 86°F (20°C and 30°C)

Relative Humidity: 95% non-condensing

Control Panel

Type: 2x20-character display with touch pad control, five LED function indicators and alarm enunciator with ring back feature.

Communications

Type: RS-232 port (DB9) standard on all models.

Physical specifications

Model Number	System Efficiency @ Full Load	Audible Noise DBA @ 1M	Heat Loss (BTU)	Number of Batteries	Battery Voltage	Max DC Current	AC Input Current				Total System Weight	
							120 VAC		277 VAC		Lbs.	Kg.
							Run	Max	Run	Max		
CIS015	97	45	75	4	48	39	13	16	5.5	7	511	233
CIS022	97	45	100	6	72	38	20	24	8.5	11	674	307
CIS030	97	45	100	8	96	38	26	32	12	14	827	376
CIS037	97	45	200	10	120	37	33	39	14	17	980	445
CIS048	97	45	245	12	144	40	42	50	18	22	1168	531
CIS060	97	45	300	15	180	40	52	63	23	27	1560	710
CIS080	97	45	400	20	240	39	69	84	30	36	2115	961
CIS100	97	45	500	24	144	82	86	105	38	45	2516	1143
CIS125	97	45	640	30	180	82	108	131	47	57	2980	1353
CIS167	97	45	840	40	240	80	144	174	62	76	3910	1775

Specifications listed are for 90 minute rated systems utilizing standard type "LC" batteries. Consult factory for specifications on models with alternate batteries and runtimes

CONTROL PANEL

The CIS system's user interface control panel provides access to the following features and functions:

Meter Functions

- AC Voltage Input
- AC Voltage Output
- AC Current Output
- Battery Voltage
- Battery Current
- VA Output
- Inverter Watts
- Ambient Temperature
- System Days (cumulative)
- Inverter Minutes (cumulative)

Program Functions

- Set Date
- Set Time
- Set Monthly Test Date and Time
- Set Annual Test Date and Time
- Set Load Fault Reduction Setting
- Set Low Battery Alarm
- Set Near Low Battery Alarm
- Set Low AC Voltage Alarm
- Set High AC Alarm
- Set Ambient Temperature Alarm

Alarms

- High Battery Charger Voltage
- Low Battery Charger Voltage
- High AC Input Voltage
- Low AC Input Voltage
- Near Low Battery Voltage
- Low Battery Voltage
- Load Reduction Fault
- High Ambient Temperature
- Inverter Fault
- Output Fault



Control Functions

Test and Event Logs: (75 logs stored) Logs record the following data: Date, Time, Duration, Output Voltage, Output Current, Ambient Temperature and Alarms Present.

Alarm Logs: (50 logs stored) Logs record the following data: Date, Time and Alarm type

5 LED Indicators and Alarms With Ring back Feature

Buzzer: On/Off (toggle)

System Testing

Systems provide both a manual and two automatic test functions. Manual tests of system operational readiness may be performed at any time by pressing the control panel test switch. Automatic self-diagnostic tests consist of a 5-minute monthly and 90-minute annual function. The date and time of automatic monthly and annual test routines are user programmable.

Battery Type	System Model Number									
	CIS015	CIS022	CIS030	CIS037	CIS048	CIS060	CIS080	CIS100	CIS125	CIS167
LC - Standard 10 Year Life	A	A	A	A	A	B	B	C	C	C
G - Premium 20 Year Life	A	A	A	A	A	B	B	C	C	C
NC - Wet Nicad 25 Year Life	CONSULT FACTORY									

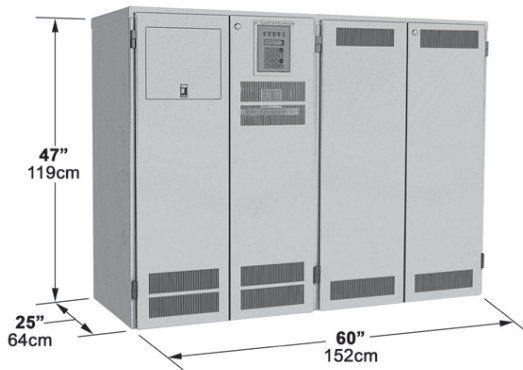

Configuration B

Configuration C

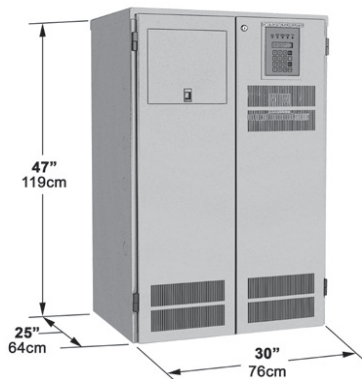
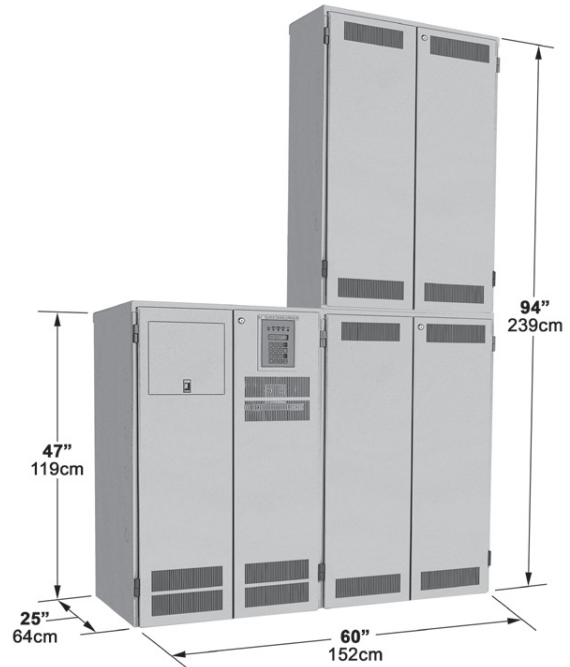

Configuration A

OUTPUT CIRCUIT BREAKERS GUIDE

B		A		20	10	T
Function		Voltage		Current Rating	Quantity²	Optional
B Norm On		A 120 volts		10-60 Amps	01 - 12	Trip Alarm
N Norm Off		B 208 volts ¹			(8 max w/alarm)	
		C 240 volts ¹				
		D 277 volts				
		G 480 volts				

¹ Double Pole breakers take up 2 positions
² Contact Factory for additional requirements

Normally-Off Output (N)

The system's output circuit is dedicated to emergency equipment only. Normally off loads operate only during power failures when the system is operating in battery mode. This option leaves connected loads off during normal utility power conditions.

Battery Charger Upgrade (CH)

The battery charger upgrade option decreases the time required to return a fully discharged battery to the fully charged state. The normal 24 hour recharge cycle is reduced to 12 hours.

Alternate Run Time (AR)

The system's normal 90-minute discharge cycle can be specified to meet decreased or increased run times in special product applications. Specify required discharge time in minutes. Example: AR (30)

External Maintenance Bypass Switch (EMBP)

The external maintenance bypass switch is supplied in a 20"H x 16"W x 9"D NEMA 1 enclosure and is a "make before break" disconnect device used to completely isolate the inverter system from the connected load. This option allows the system to be safely powered down for maintenance or service without interruption of utility power to the connected load. The option may not be specified on systems with more than one single pole output circuit breaker which must be sized for the total system output current.

Inverter On Form C Contacts (IO)

Provides summary form C relay contacts that monitor inverter operation. Supplied with both normally-open and normally-closed contacts that change state upon inverter activation. Contact ratings are 5 amps maximum at 250VAC/30VDC.

Summary Form C Contacts (S)

Summary form C low power contacts allow connection points for alarm relay outputs for remote monitoring purposes. Rated at 5 amps (250VAC/30VDC), the contacts will change state with the activation of the following alarms: High/Low Battery Charger Voltage, High/Low AC Input Voltage, Near Low Battery Voltage, Low Battery Voltage, Load Reduction Fault, High Ambient Temperature, Inverter Fault, Output Fault, Output Overload as well as with optional circuit breaker trip alarms if supplied.

Internal Maintenance Bypass Switch (M)

The Internal Maintenance Bypass Switch is a make-before-break manual switch that allows the system to be bypassed during routine maintenance allowing egress lighting to remain on for safety.

Time Delay (TD)

A 15 minute delay during retransfer allows normally off emergency lighting to remain on while power stabilizes and ambient lighting, such as HID, has time to reach full brightness.

Internal Dimmer Bypass (IDB)

Provides a means to bypass local dimming circuits and return emergency lighting fixtures to full brightness.

Battery Cycle Monitor (BCM)

In depth battery monitoring circuitry to evaluate battery condition and health. See brochure for full details.

Seismic Bracing Kit (Z)

The seismic bracing kit option is designed to prevent system movement during seismic events. Heavy duty brackets are provided to secure system cabinetry to floor surfaces. Meets Zone 4 requirements.

NOTE: For reasons of safety, system cabinetry may not be stacked on models specified with SEISMIC option.

External Modem (MOD)

The external modem is designed to boost the signal level of the RS-232 communications interface to remote monitoring locations more than 100 feet away from the system location.

Internal Fax Modem (FAX)

The internal fax modem automatically provides notification of routine self diagnostic test results and alarm conditions to up to eight pre-programmed phone number locations. The fax modem option may also be used to perform a variety of system functions via phone line through the system's RS-232 communications interface. Option includes computer module, modem card, factory installed software and all connection cables. The Fax Modem option requires a user supplied dedicated analog phone line.

Auto Dialer (A)

The Auto Dialer modem option automatically dials up to four user programmable phone numbers in the event of any system alarm condition. The option is designed to deliver a predetermined digital or audible message when activated. The Auto Dialer option requires a user supplied dedicated digital or analog phone line.

Simple Network Monitoring Protocol (SNMP)

The -SNMP option consists of an externally mounted box that provides a communications interface between the inverter system's RS-232 port and an Ethernet 10BASE-T local area network. The option allows LAN monitoring of system status and all operating parameters. LAN servers with VPN remote access further allow system status monitoring via the World Wide Web.

Remote Meter Panel (RMP)

Allows remote monitoring of system status and all operating parameters from locations up to 300 feet away from the inverter system. Additionally, the panel provides a complete touch pad interface allowing the user to monitor, control and program the inverter system remotely.

Remote Summary Alarm Panel (RSP)

Remote alarm annunciator panel provides a visual and audible indication of system status and alarm conditions. The panel option which consists of five LED indicators and built in audible alarm may be located up to 1,000 feet away from the inverter system. Option requires user supplied two-conductor, 20AWG interconnecting cable.

Status Monitoring Contacts (SMC)

Form "C" dry contacts capable of monitoring system and option statuses. Conditions monitored include Inverter On, Inverter off, AC present, High Temperature, Summary Alarm, System Bypass and Output Circuit Breaker Tripped.

Extended Warranty (EW)*

Extends standard one year factory warranty up to an additional four years. Includes Factory Start-Up Service.

Factory Start-Up (FS)*

Initial on-site power up and test of inverter system and accessories performance to factory specifications by the manufacturer's local authorized service representative. Includes one additional year of warranty.

* Warranty extensions apply to system electronics only. System batteries are covered by a separate pro-rata warranty which remains unchanged.