

Fixture Type:	
Model Number:	
Project:	

## BNXL Series Wet Location Emergency Lighting

### ORDERING GUIDE

**BNXL - B**

**OPTIONS**  
B Black housing



### ILLUMINATION

- Sealed and gasketed weather proof lamp heads with tempered glass lenses.
- Long lasting efficient ultra-bright white LED
- High-performance chrome-plated metalized reflector for optimal light distribution.
- Adjustable lamp heads provide optimal center-to-center spacing
- Can operate up to 2 additional remote heads - 9.6 VDC, 3 Watts max

### AGENCY APPROVALS

- Meets UL924, NFPA 101 Life Safety Code, NEC, OSHA, Local and State Codes.
- UL listed for wet locations. (5°C – 40°C)

### DIMENSIONS

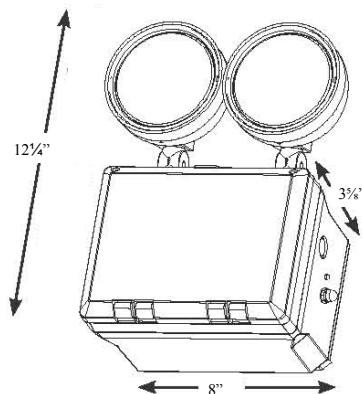

### STANDARD FEATURES

- Corrosion-resistant 5VA flame retardant, UV-stabilized polycarbonate in gray finish.
- Sealed and gasketed housing with hinged cover.
- Sealed test switch.
- Integral breather vent.
- External mounting brackets for simplified wall mounting provided.
- Designed for non-hazardous applications
- Ideal for parking garages, car washes and outdoor areas
- Universal 120/277volt input
- Solid state two rate charger technology
- Low voltage disconnect
- AC lockout and brownout protection
- Overload and short circuit protection.
- Test switch and charge indicator
- Premium, maintenance-free sealed NiCAD battery
- Minimum of 90 minutes of emergency time
- Cold weather feature available for freezer applications (-20°C to 50°C)

### WARRANTY

Five year warranty on all electronics and housing. Batteries are pro-rated warranted for two years.

**Carpenter Emergency Lighting**  
Phone: 609-689-3090 Fax: 609-689-3091

**2 Marlen Dr., Hamilton, NJ 08691**  
[www.carpenterlighting.com](http://www.carpenterlighting.com)